

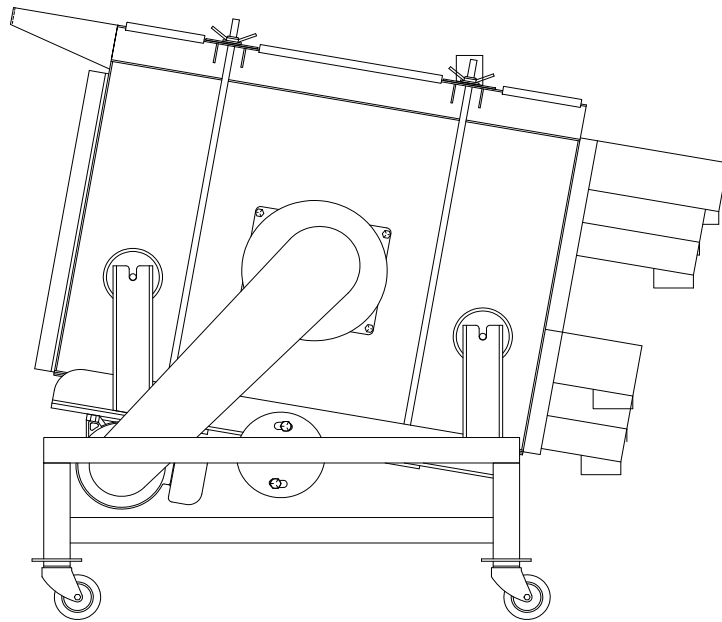

SMICO FRACTIONATOR

MANUAL



IMPORTANT!

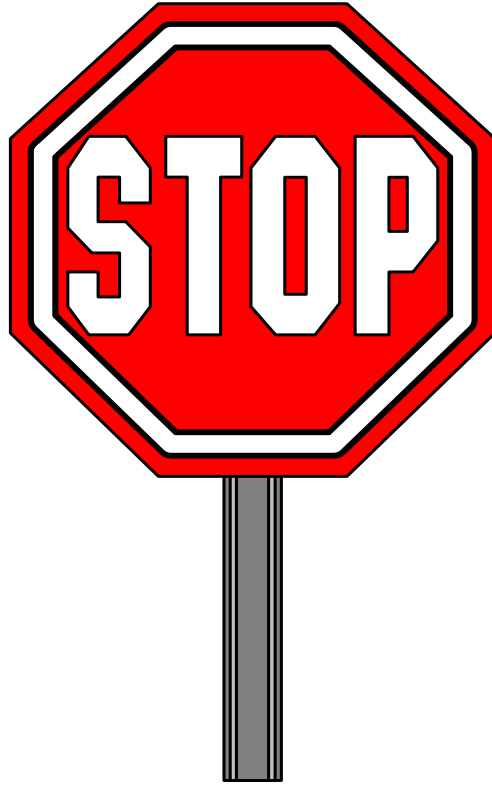

SCREENER STORAGE

**Long Term Storage greater than
60 days may cause damage to
vibrator drive components.**





IMPORTANT

Before operating your STACKABLE VIBROSET series screener, be sure to remove the transit bracket from the spring mounts. These brackets have been provided to minimize damage to the shaker while in transit. Failure to remove these brackets before operation of your screener could result in damage to the screener as well as the surrounding structure. Retain these brackets for use when moving or re-shipping the unit.

The spring mounts on the machine provide vibration isolation for this machine.

DO NOT attempt to further isolate this machine by using some type of vibration isolator between the frame and the foundation. This will result in a frame that is not rigid and the machine will vibrate this frame excessively. This will usually produce more vibration transmission rather than less vibration transmission.

HOPPERS

In erecting a hopper beneath the screen, be sure the valley angles are steep enough to give a free flow of the material being screened. See that the hopper is built low enough so the live machine structure will not strike the hopper, even when the machine is set at the steepest angle. Also note the screener will have random and erratic movement during start up and shut down. Allow an extra 2" minimum around the live machine to allow for this movement.

DISCHARGE CHUTES

In designing discharge chutes the valley angles and clearances specified in the hoppers paragraph needs to be taken into account. In addition to that, the screens are removed from either end. This will require access to the end of the unit, and screen cloth removal will require the length of the screen panel beyond the machine.

If a dust seal is required, the use of flexible connectors is the best method of accomplishing this. This type of connector must be flexible enough to allow free movement of the live unit without restrictions. NOTE: Connectors, which are stiff, may cause excessive vibration transmission to the surrounding structure, damage the screener, and alter the screening efficiency.

FEED CHUTES

Feed chutes must also conform to the specifications specified in the hopper paragraph. In addition to that feed chutes are an important part of the screener.

Feed chutes should provide for distribution of the material across the full width of the machine. Feed chutes should limit the fall of the material as much as possible. They should also slow up fast moving streams. These aspects will allow for efficient screening of your product. Proper

feed chutes will adequately repay for the time spent constructing them by reducing screen cloth wear and increasing the efficiency.

CONNECTIONS

The connections between the STACKABLE VIBROSET series screener and the matching chute work needs to be via a flexible connector. The distance between the two spouts needs to be 2 - 3 inches. This distance allows the machine the room necessary for start up and shut down. The connection between the two needs to be a flexible connector held in place by clamps. On a rectangular spout the boot are held on by a clamp bar with bolts and welded nuts on the inside of the spout. On a round or elliptical spout a hose clamp type fastener is all that is needed to hold the boot in place.

For abrasive applications it is necessary to have a stand off between the spouts and the boots. This stand off will insure the product does not come in contact with the boot preventing the product from prematurely wearing the boot.

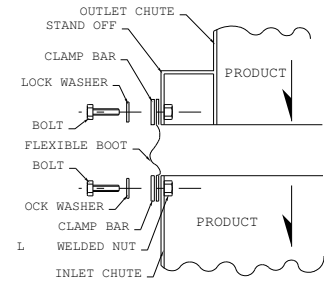

Rectangular boot connection with clamp bars and fasteners

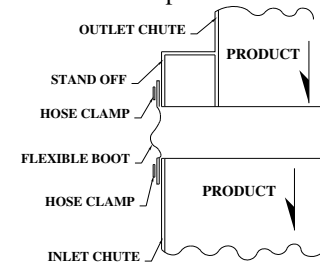

Round or elliptical boot Connection with hose clamp

CONTROL YOUR PRODUCT

Your STACKABLE VIBROSET series screener is fully adjustable to your product; Take full advantage of these exclusive features so you may obtain the most efficient results possible. Be sure the stroke, speed, and the angle of the machine are correct for your product. Do not guess! Check it!

BALANCE

SMICO STACKABLE VIBROSET series of screeners is dynamically balanced. The shaking weight of a dynamically balanced machine is counter balanced by the rotating counter weights, on the shaft, to produce the vibrating effects that are uniform across the entire screen area. This motion is affected by the loading of the machine and dramatic surge loading of the machine could produce undesired effects.

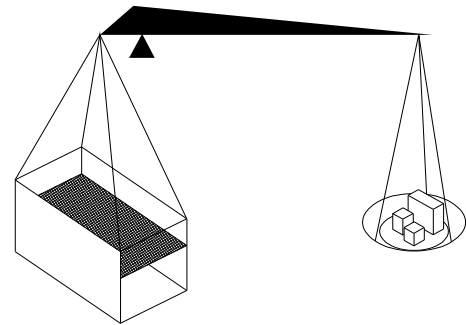

The weight of the machine is accurately counterbalanced. These counter weights are attached to the shaft via the eccentric wheels and the balance wheels, and are not to be changed unless additional weight is added to or removed from the machine. If weight is added or removed from the machine contact the factory for assistance in adding or subtracting counterweight. **NOTE: DO NOT** add skirt boards, wearing plates, chutes, feeders, or any other material to the live part of the machine. These structures will be subject to extreme dynamic forces and fatigue; In

addition, they will change the balance of the screen. Such unbalance could cause serious problems such as premature bearing failure, destroying the motor, and transmitting excessive vibration to the structure, and other similar undesired effects.

ANGLE

The inclination at which the screening surface is operated plays an important part in the screening efficiency. If the angle is too great the material will pass over too rapidly, and will not be properly graded. If the angle is too slight efficient grading may not be maintained, the capacity of the screen will be reduced, and material will tend to accumulate at the feed end of the machine, causing undue wear and breakage of the screen cloth. Proper inclination of the screen provides efficient grading and capacity.

Tests have indicated on some materials a 5° difference on inclination has caused a variation in recovery as great as 90%.

The deck construction or screen body is held in position by springs at each of the four corners of the machine. These springs should be vertical during operation. Consult the factory for more than minor changes in the inclination.

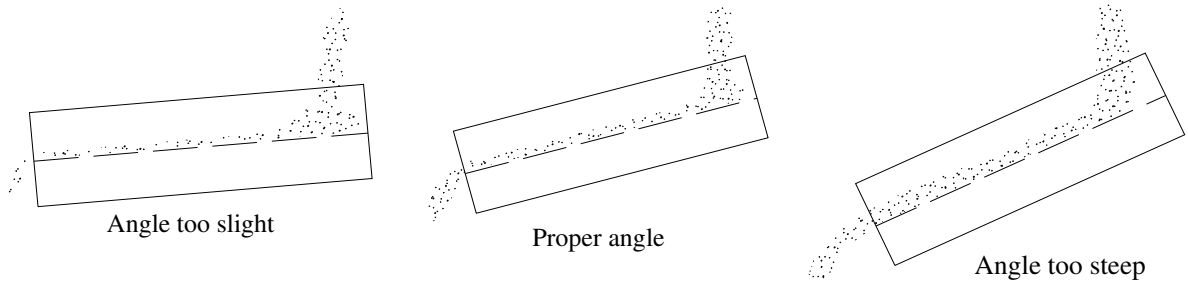

STROKE

The STACKABLE VIBROSET series of screeners vibrates in a circular pattern. The diameter of this circle is called the stroke. The stroke can be measured in one of two ways. First, a dot can be placed on the side of the machine and the diameter of the circle the dot makes when the machine is in operation is the stroke. Second, a stroke gauge can be used to determine the stroke.

A small stroke gauge is made up of a number of circles with specific diameters. One of those diameters must correspond to the stroke of the machine. The diameter of the circles corresponds to the number below the circle. When this gauge is placed on the side of a machine the circles will blur. There will be one blurred circle where the center of the blurred circle is a solid point. The diameter of that circle will be the stroke.

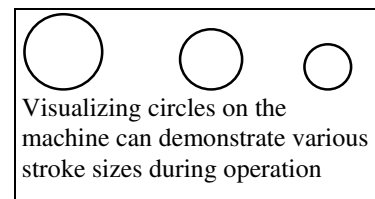

The STACKABLE VIBROSET series of screeners are equipped with an adjustable eccentric, the variation in range being indicated by numbers running consecutively from zero to four. The screens are set at the factory at the throw estimated, from our experience, to be approximately that desirable for the particular product. After the machine has been installed and operated at the setting made by the factory, it is desirable from the standpoint of efficiency in screening that you try at least one or more number setting on either side of that made by the factory, checking your product at each instance. Reports made of investigations by independent sources show variations of as much as 20 percent on a difference of one or two numbers on throw setting. Speed will, of course, compensate with throw within certain ranges. Normally the greater the throw the lower the speed required for efficient operation, and the finer the particle, the greater the speed and the finer the eccentricity required.

STROKE CHANGE

The stroke amplitude (eccentricity) is adjustable in four different settings (1) .0625, (2) .125, (3) .1875, (4) .250.

To change stroke (both sides):

1. Remove the Drive Bushing (item 1), Sheave (item 2) and the k-16 Aluminum cover (Item 3).
2. Remove the bolts holding the K-6 Eccentric Ring from the K-7 Fly-Wheel.
3. Screw two 3/8-24 thread 1-1/4" bolts into the K-6 tapped holes to loosen the Taperlock from the K-7.
4. Note the "O" or "Single Line" on the rim of the K-6 Eccentric Ring. This must be in line with the desired stroke number 1 to 4 which is marked on the K-7 Fly-Wheel.
5. Rotate the K-6 (both sides) to the new stroke number and rebolt the K-7.

NOTE: Be sure the K-6 is up against the shaft shoulder and lock K-6 to the K-7. Rap (use brass) K-6 after tightening and again check tightness to insure tight fit of Tapers.

6. After carefully checking and verifying the numbers to see that both sides are set at the identical number, replace the K-16 cover (Item 3), Sheave (item2) and Bushing (item 1).

SPEED

The speed plays an important part in screen operation within certain ranges. Discretion must be used in the selection of the speed-stroke combination. The tests carried out by independent organizations indicate that in general, speeds in excess of 1600 RPM have little effect on the efficiency or capacity of the screen.

STACKABLE VIBROSET series screeners operate at speeds from 800 - 1500 RPM, and they normally operate with strokes from 1/8" - 1/4". The speed is inversely related to the stroke for energy limits.

For example:

1/8" stroke	1300 - 1600 RPM
3/16" stroke	1200 - 1300 RPM
1/4" stroke	1000 - 1200 RPM
3/8" stroke	800 - 1000 RPM

These machines should not be operated outside these limits. If the speed is too slow the machine will not operate at maximum capacity; yet if the speed is too great the bearings will become overloaded, which results in premature bearing failure.

Generally, a stroke of 3/16 and a speed of 1250 RPM are efficient in screening most materials. In other cases a slower speed with larger stroke works well for larger size material, and faster speed with smaller stroke works well for smaller material.

Speed on a STACKABLE VIBROSET series screener may be controlled in either of two ways. First, using a variable speed motor or motor controller can control the speed. Second, the speed can be changed by sheave selection. Single speed v-type sheaves are standard on SMICO series screeners. These sheaves are sized to give the speed our tests and experience indicates most desirable for the job.

If you need further information on speed changes, consult the factory.

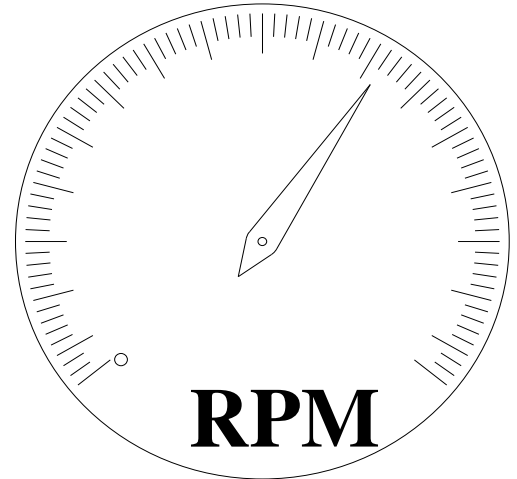

SCREEN CLOTH

The SMICO STACKABLE VIBROSET series of screeners is a high-speed machine. Screen cloths are installed in the factory on deck frames by either epoxy or welding.

Screen cloth selection is very important in order to obtain proper results, to eliminate screening problems, and to avoid costly maintenance and replacement. Screen cloth should be selected by considering three aspects.

FIRST:

The first aspect is maximum open area. When the open area is maximized, the capacity and efficiency of the screen are at their peak; however, the screen life is greatly reduced, and frequent replacement will be required. Decreasing the wire size used in making the screen cloth can increase the open area of a screen cloth.

SECOND:

The second aspect is maximum screen life. When screen life is at its maximum, the life of the screen is increased causing less frequent screen replacement, and fewer down times; however, when screen life is high the capacity of the screen is low. Increasing the wire size used in making the screen cloth can increase screen life in a screen cloth.

THIRD:

The third aspect is corrosion resistance. With a high corrosion resistant screen the screen will hold up longer from chemical materials such as water or acid; yet, a screen with a high corrosion resistance is costly, and may be hard to locate, and have a long delivery schedules.

In addition to this, specialty screens can be furnished for your particular needs. Some of these types of screens are perforated plate, slotted screens, music wire screens, flat top screens, synthetic screens, and many others. If you need further information on screen cloth selection consult the factory.

SCREEN CLOTH REMOVAL



and spacers.

1. Open the feed inlet and discharge end plates.
2. Loosen the two vertical tension rods on each side. These are the rods —————
holding the Feed Box, Screen Decks and Spacers in the stack. The hand nuts should be backed off sufficiently to allow easy sliding of screen panels



3. Stand at the end of the machine and slide the screen out, pulling it squarely toward you.

SCREEN CLOTH INSTALLATION

1. The inside of the screen body should be thoroughly washed or wiped clean. Be sure that all surfaces are free from debris and that there are no cuttings or other foreign material caught beneath the screen when it is installed.

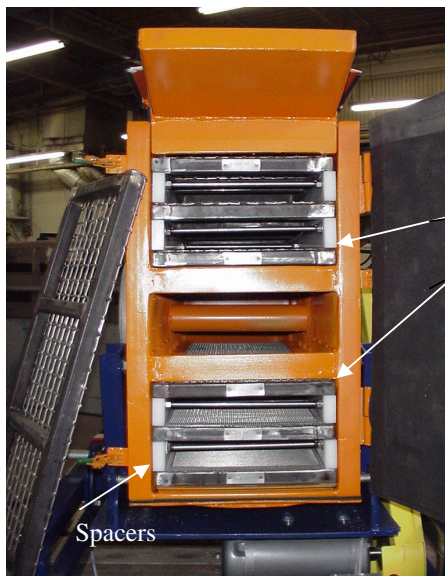

2. Make sure the lower ball deck frame is in place above the pan.
3. Now insert the screen decks and spacers. Install three screen decks and two spacers below the lower fixed rail; install three screens and two spacers with feed box above upper guide rail.
4. Verify the screener decks and spacers are in place and flush with each end of the screener.
5. Tighten the four vertical tensioning rod hand nuts so that there is an equal amount of tension on all four corners.
6. Close and Lock the end plate.

LUBRICATION

The SMICO STACKABLE VIBROSET series of screeners is supplied with factory lubricated and sealed bearings. It is not necessary to lubricate bearings at any time. For replacement, see page 13.

BEARING REMOVAL

1. Disconnect the power to the motor and Tag out/Lock out the motor power.
2. Remove the belt guard and belt.
3. Remove the drive sheave, bushing and Aluminum Cover K-16.

4. Remove lock wire and bolts on K-6 to K-7. Screw two 3/8-24 thread 1 1/4" bolts into the K-6 tapped holes to aid in removing the K-6 balance wheel (item 4) from the K-7 Taper fit.
5. Pull off the K-7 Eccentric Wheel (item 6) off the O.D. of the bearing by using a standard puller with plug in the end of the K-2 shaft housing (item 11). This is a transitional/slip fit.
6. Remove K-4 bearing (item 8) by using a standard puller and drawing forward from the K-2 bearing housing. The K-4 bearing to K-2 housing is a press fit.

BEARING INSTALLATION

1. When purchasing a bearing, please verify the number of the bearing you are purchasing matches the number of the bearing you are replacing.
2. Press K-4 bearing onto the journal of the K-2 shaft housing. Bearing is a press fit and should be pressed until it sets on the shoulder.
3. Reassemble the K-6 & K-7, eccentric wheel and balance wheel, with the K-1 shaft in the reverse order as removed.
4. Set endplay by positioning the K-6 up against the K-1 shaft shoulder and lock the K-6 to the K-7. Rap (use brass) the K-6 after tightening and again check tightness to insure fit of Tapers. The endplay is built into the shaft shoulder length and should provide a minimum of 1/16" play. If endplay is not present, consult the factory before operating machine.
5. Reinstall K-16 guard cover and drive component in the reverse order as removed.

STACKABLE VIBROSET DRIVE PARTS LIST

ITEM	QTY	DESCRIPTION	PRINT #	PART NO.	REF #
1	1	QD SDS BUSHING	N/A	See Page 12	
2	1	QD SHEAVE	N/A	See Page 12	
3	1	K-16-D, DRIVE GUARD	18157	301-309-003	301-309-002
4	2	K-6, BALANCE WHEEL	15738	301-306-003	301-306-002
5	1	K-7, ECCENTRIC WHEEL	17113	301-307-003	301-307-002
6	1	K-24, DRIVE KEY	N/A	301-305-016	301-305-012
7	4	K-8, COUNTERWEIGHTS	16338	*	
8	2	K-4, BEARING	N/A	304-010	301-304-002
9	2	K-3, VIBRATOR BRACKET	15040	301-303-003	
10	1	K-1, DRIVE SHAFT 12"	16332-F/R	301-301-122	
11	1	K-2, SHAFT HOUSING 12"	16333-F/R	301-302-123	
12	1	K-16-B, BLIND GUARD	18156	301-309-002	
13	1	K-25, BLIND SIDE KEY	N/A	301-305-011	301-305-001
14	6	SAFETY BOLT	15041	301-305-001	
15	2	SAFETY WIRE	N/A	N/A	

*Consult Factory for appropriate sizes for your machine



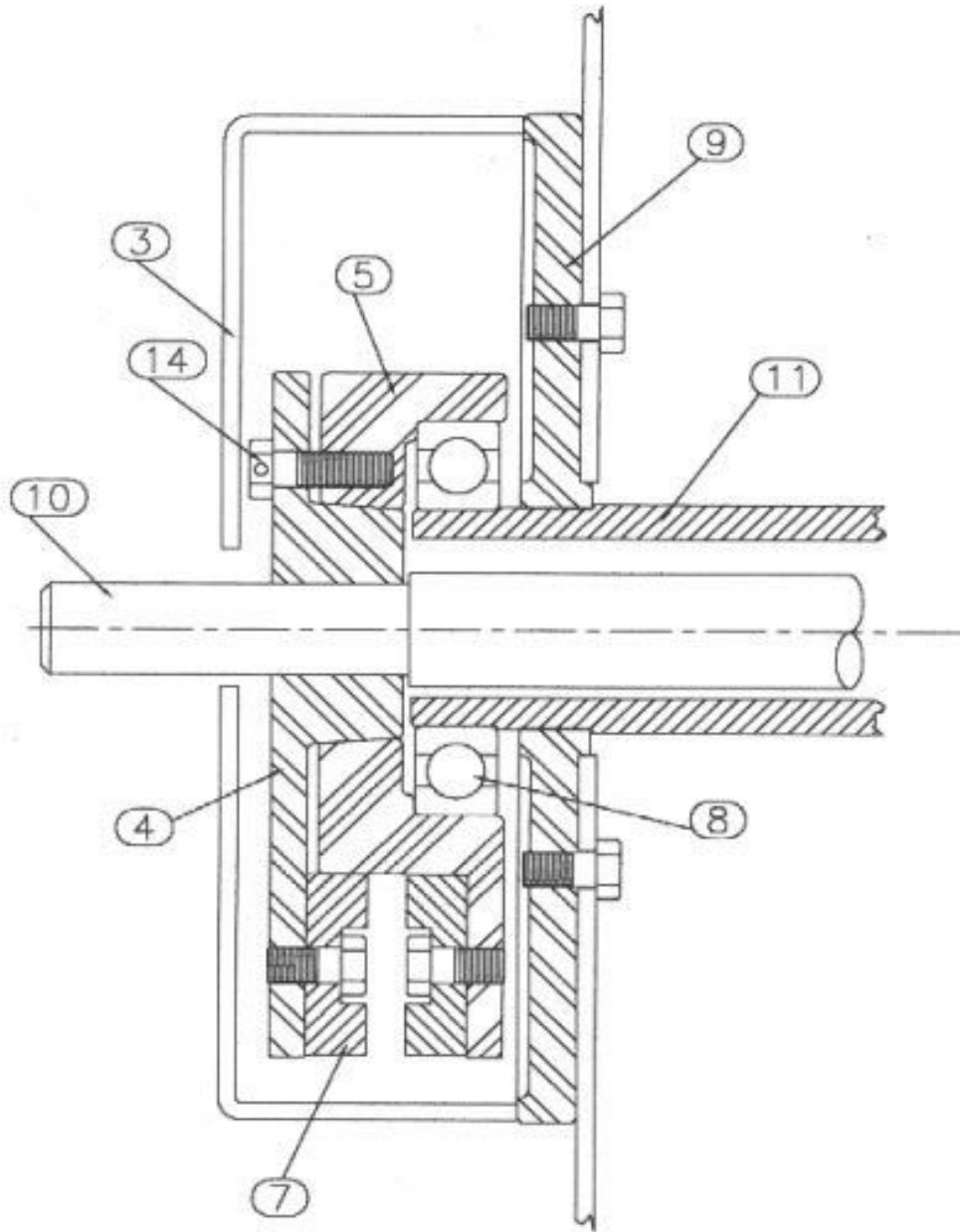

ADDITIONAL SPARE PARTS LIST

Part Number	QTY	DESCRIPTION
775-500	1	Reversing Drum Switch
700-84321-1	1	1 C.O. - .3.76 mm dia wire screen x 12 x 36
700-84321-3/4	1	3/4 C.O. – 3.43 mm dia wire screen x 12 x 36
700-84321-1/2	1	1/2 C.O. – 2.67 mm dia wire screen x 12 x 36
700-84321-3/8	1	3/8 C.O. – 2.34 mm dia wire screen x 11 1/2 x 36
700-84321-4	1	4 Mesh – 1.58 mm dia wire bonded screen x 12 x 36
700-018	1	8 Mesh – 1.00 mm dia wire bonded screen x 12 x 36
SPARE/700-019	1	16 Mesh - .016 dia wire bonded screen x 12 x 36
84171	4	Rubber mount (Springs)
360-038	1	Motor Sheave
360-054	1	Drive Sheave
343-088	1	Motor Bushing
341-100	1	Drive Bushing
775-505	4	Clamping Knobs
251-190	2	18" split Teflon tubing
251-190	4	7 1/2" split Teflon tubing
260-130	20	1 3/8 Dia Rubber Ball Cleaner
84174	4	4" Caster w/brake
775-530	Set	UHMW Deck Spacers